

# INSTRUMENT PANEL

## 1996 Toyota Supra

1995-96 ACCESSORIES & EQUIPMENT  
Toyota Instrument Panels

Supra

### DESCRIPTION & OPERATION

**WARNING:** Deactivate air bag system before performing any service operation. For 1995 Supra, see AIR BAG RESTRAINT SYSTEM, for 1996 Supra, see AIR BAG RESTRAINT SYSTEM article. DO NOT apply electrical power to any component on steering column without first deactivating air bag system. Air bag may deploy.

### GAUGES

Standard instrument clusters contain fuel and temperature gauges with telltale warning lights. Some optional instrument panels are equipped with a tachometer, oil pressure gauge and voltmeter. Gauge internal operating components use either a 2-terminal bimetallic strip type, or a 3-terminal coil type. The 2-terminal type gauges are generally used on clusters without tachometers.

### SWITCHES

All models contain hazard warning switch on instrument panel. All models use a combination switch for headlight, turn signal, wiper/washer, and cruise control switches. Combination switch is mounted on steering column. For testing and/or removal and installation procedures for combination switch components, see appropriate STEERING COLUMN SWITCHES article.

### COMPONENT TESTS

#### FUEL GAUGE & WARNING LIGHT

Fuel Gauge & Wiring Harness Operational Test

1) Unplug fuel tank sending unit connector. Turn ignition on. If fuel gauge indicates EMPTY, go to next step. If fuel gauge does not indicate EMPTY, repair short circuit in wiring harness. See WIRING DIAGRAMS.

2) Connect a 12-volt, 3.4-watt test light between appropriate terminals of sending unit wiring harness connector. See Fig. 1. See FUEL GAUGE & HARNESS TEST table.

3) With ignition on, test light should flash and gauge needle should move toward FULL. If test light does not flash and gauge needle does not move, check wiring harness for open circuit. Repair or replace as necessary. If wiring harness checks good, replace fuel gauge.

#### FUEL GAUGE & HARNESS TEST TABLE

Model	Sending Unit Connector Terminals No.
Supra .....	1 & 3



96D07017

Fig. 1: Identifying Fuel Sending Unit Harness Connector Terminals  
Courtesy of Toyota Motor Sales, U.S.A., Inc.

#### FUEL SENDING UNIT TESTS

Fuel Sending Unit Resistance Test

1) Turn ignition off. Remove fuel sending unit from tank. Connect ohmmeter to appropriate sending unit terminals. Refer to the FUEL SENDING UNIT CONNECTOR TERMINALS table. Sending unit connector terminals are located opposite harness connector terminals.

See Fig. 1.

2) Move sender arm and ensure resistance is within specification. See FUEL SENDING UNIT RESISTANCE SPECIFICATIONS table. After a short delay, gauge pointer should move when sender is connected and float arm is moved.

FUEL SENDING UNIT CONNECTOR TERMINALS TABLE

---

Model	Sending Unit Connector Terminals No.
Supra .....	2 & 3

---

FUEL SENDING UNIT RESISTANCE SPECIFICATIONS TABLE

---

Float Position	Ohms
Full .....	4
Half .....	55
Empty .....	107

---

Low Fuel Warning Light Sensor Operational Test

1) Remove fuel sending unit from gas tank. Using a battery, connect voltage to warning light sensor terminals of sending unit connector. See LOW FUEL WARNING LIGHT SENSOR TERMINALS table.

2) Connect a 12-volt, 3.4-watt test light between positive battery terminal and one warning light sensor terminal of sending unit connector. Connect other warning light sensor terminal to negative battery terminal.

3) With sending unit float/sensor dry, test light should come on within about 40 seconds. With sending unit float/sensor submerged in gasoline or water, test light should not come on. If test light does not function as described, reverse wire connections at battery terminals and retest. If test light still does not function as described, replace sensor or complete sending unit.

LOW FUEL WARNING LIGHT SENSOR TERMINALS TABLE

---

Model	Sending Unit Connector Terminals No.
Supra .....	1 & 3

---

Fuel Gauge Resistance Test

Remove instrument cluster. Unplug cluster connector(s). Using an ohmmeter, check fuel gauge resistance by measuring across appropriate terminals. See FUEL GAUGE RESISTANCE SPECIFICATIONS table. See Fig. 2. Replace fuel gauge if not within specifications.

FUEL GAUGE RESISTANCE SPECIFICATIONS TABLE

---

Application & Terminals	Ohms
Terminals "A" & "B" .....	270
Terminals "A" & "C" .....	124
Terminals "B" & "C" .....	146

---

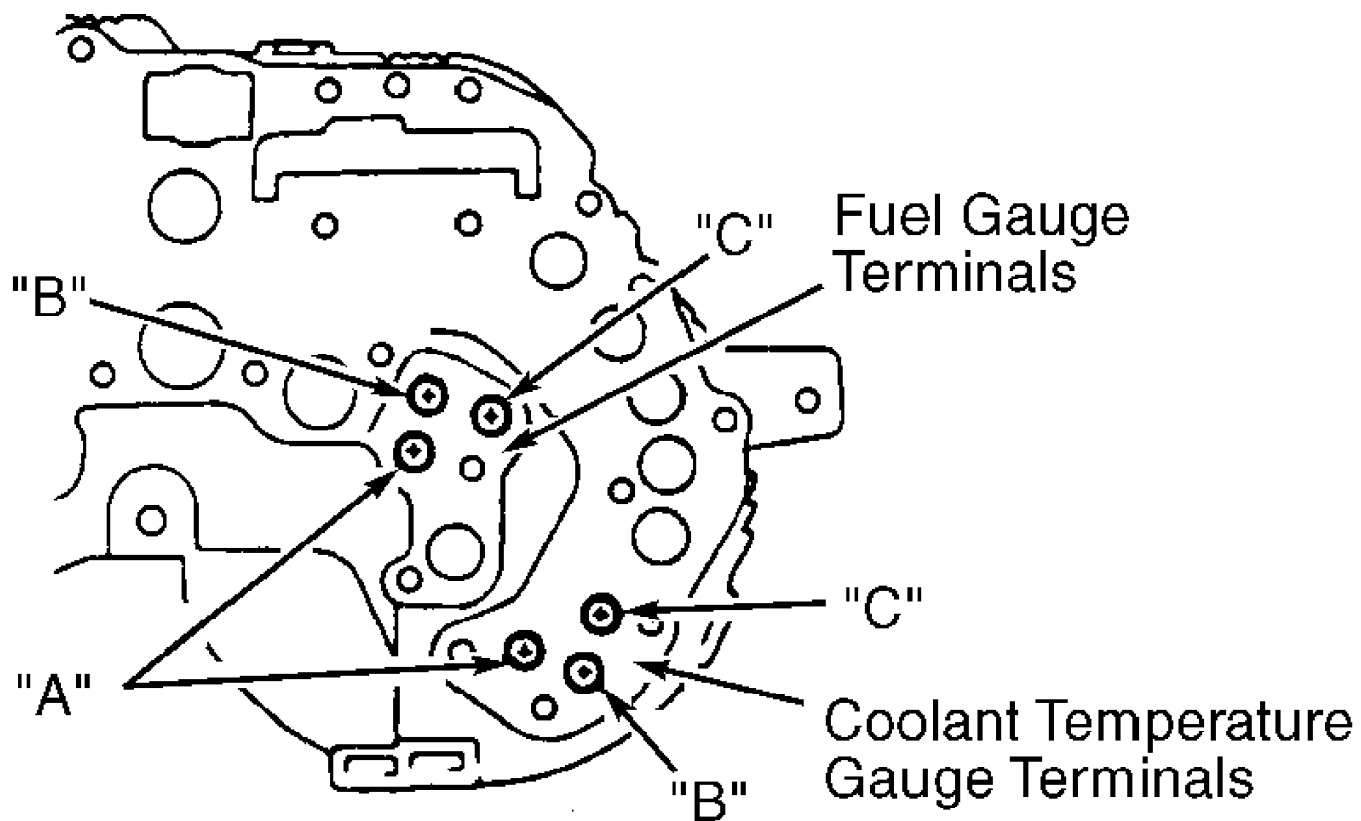

93J84557

Fig. 2: Identifying Fuel/Temperature Gauge Terminals  
 Courtesy of Toyota Motor Sales, U.S.A., Inc.

### TEMPERATURE GAUGE & SENDER TESTS

#### Wiring Harness Operational Test

- 1) Unplug connector at coolant temperature sender. Turn ignition on. Temperature gauge should indicate COOL. Turn ignition off. Connect a 12-volt, 3.4-watt test light between coolant temperature sender harness connector terminal and ground.
- 2) Turn ignition on. Test light should glow and temperature gauge should slowly move to HOT. If gauge functions as described, replace sending unit. If gauge does not function as described, perform TEMPERATURE GAUGE RESISTANCE TEST below.

#### Temperature Gauge Resistance Test

Remove instrument cluster. Using ohmmeter, check gauge resistance across appropriate terminals. See Fig. 2. Ensure ignition is off and harness connector is unplugged from instrument cluster. See TEMPERATURE GAUGE RESISTANCE SPECIFICATIONS table. Replace gauge if not within specification. If gauge is within specification, repair open or short circuit in wiring harness.

#### TEMPERATURE GAUGE RESISTANCE SPECIFICATIONS TABLE

Application	Ohms
Terminals "A" & "B" .....	230
Terminals "A" & "C" .....	54
Terminals "B" & "C" .....	176

## LOW OIL PRESSURE SWITCH & WARNING LIGHT TESTS

### Low Oil Pressure Switch

Unplug low oil pressure switch connector on engine. Using an ohmmeter, check for continuity between oil sending unit and ground. Continuity should exist with engine off. Continuity should not exist with engine running. If continuity is not as specified, replace low oil pressure switch.

### Low Oil Pressure Warning Light

Unplug low oil pressure switch connector on engine. Connect low oil pressure switch connector to ground. Turn ignition on. Low oil pressure warning light should come on. If low oil pressure warning light does not come on, check bulb or inspect wiring harness. See WIRING DIAGRAMS.

## TACHOMETER TEST

Connect a tune-up test tachometer and start engine. Compare vehicle tachometer RPM reading against test tachometer. If vehicle tachometer reading is outside allowable range, replace tachometer. See TACHOMETER TEST SPECIFICATIONS table.

TACHOMETER TEST SPECIFICATIONS TABLE

Vehicle RPM Reading	Allowable Range
700 .....	630-770
1000 .....	915-1115
2000 .....	1920-2220
3000 .....	2890-3350
4000 .....	3940-4400
5000 .....	5025-5425
6500 .....	6650-6950
7000 .....	7025-7625

## HAZARD WARNING SWITCH TEST

1) Ensure HAZARD-HORN and/or TURN fuses are good. Ensure flasher is good. See TURN SIGNAL FLASHER LOCATION table. With hazard warning switch removed from dash, ensure voltage is at switch wiring harness connector terminal No. 8. See Fig. 3. If voltage does not exist, check/repair fuses and wiring circuit. If voltage exists, disconnect switch from connector.

2) Using DVOM, ensure switch continuity exists between indicated terminals with switch in specified position. Refer to the HAZARD WARNING SWITCH CONTINUITY TEST table. If continuity is not as specified, replace switch. If continuity is as specified, check wiring circuit. See WIRING DIAGRAMS.

TURN SIGNAL FLASHER LOCATION TABLE

Model	Location
Supra .....	Top Relay In Relay Block No. 4, Behind Left Kick Panel

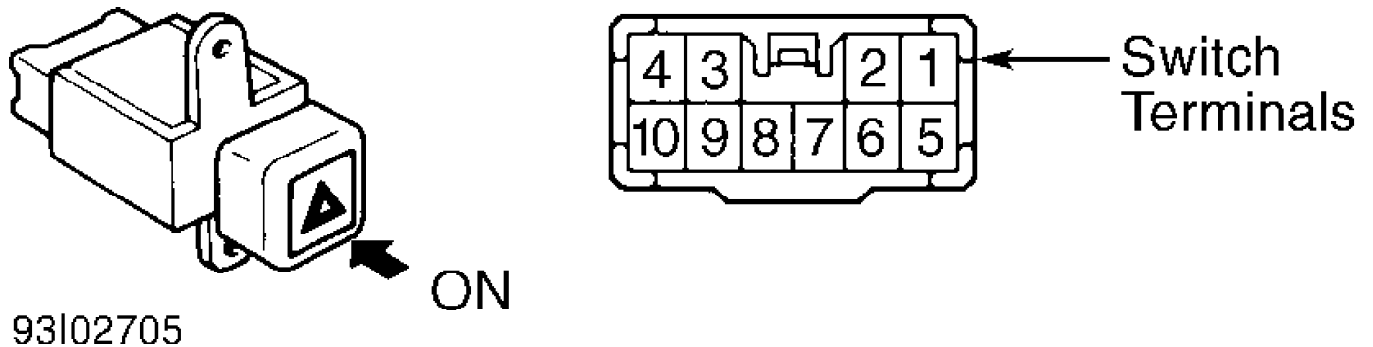

Fig. 3: Identifying Hazard Warning Switch Terminals  
 Courtesy of Toyota Motor Sales, U.S.A., Inc.

**HAZARD WARNING SWITCH CONTINUITY TEST**

Switch Position	Terminal Numbers	Continuity
Supra (1)		
Off	7 & 10	Yes
On	4, 5, 6 & 9; 7 & 8	Yes

(1) - Terminals No. 2 and 3 are for switch illumination bulb.

**REMOVAL & INSTALLATION**

**WARNING:** Deactivate air bag system before performing any service operation. For 1995 Supra, see AIR BAG RESTRAINT SYSTEM, for 1996 Supra, see AIR BAG RESTRAINT SYSTEM article. DO NOT apply electrical power to any component on steering column without first deactivating air bag system. Air bag may deploy.

**HAZARD WARNING SWITCH**

**Removal & Installation**

Hazard warning switch is mounted to center cluster finish panel, above center A/C vent. Switch is snapped into panel. Carefully pry switch out from panel and disconnect connector. To install, reverse removal procedure. Ensure switch is bottomed in dash panel.

**INSTRUMENT CLUSTER**

**CAUTION:** When removing driver-side air bag, DO NOT pull on air bag wiring harness. When storing air bag, ensure pad surface faces upward.

**Removal & Installation**

1) Disable air bag system. Remove steering wheel. See STEERING WHEEL & AIR BAG. Remove steering column covers. Remove hood release lever and retaining screw covers from instrument panel lower finish panel. Remove 2 bolts and 2 retaining screws to remove instrument panel lower finish panel and panel pad behind finish panel. See Fig. 4.

2) Remove 5 screws retaining instrument cluster finish panel and remove panel. Pry center cluster finish panel and left and right cluster finish panels from instrument panel. Pull instrument cluster out far enough to disconnect harness connectors and speedometer cable (if equipped). Remove instrument cluster. To install, reverse removal

procedure. Before installing steering wheel, center spiral cable.

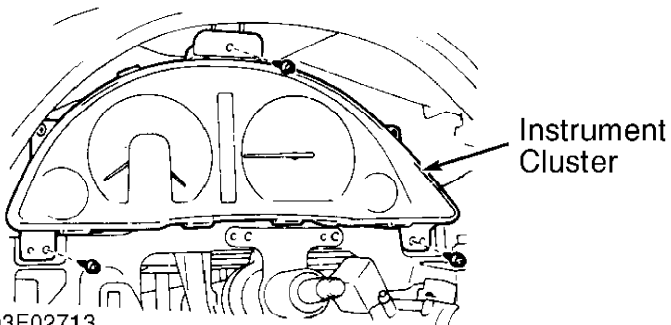
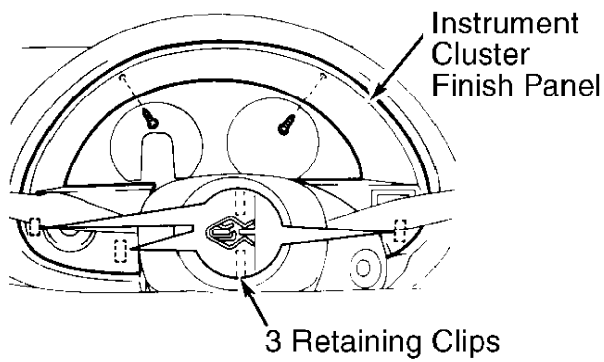
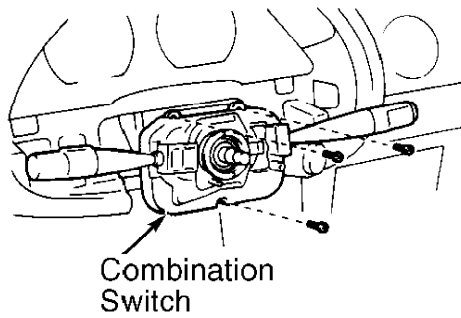
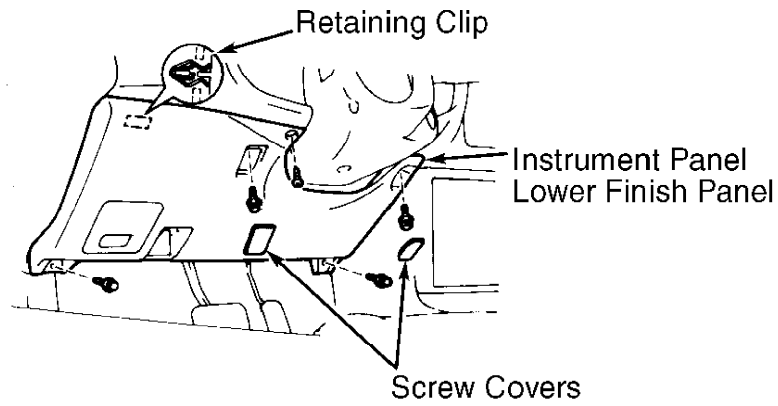

93E02713

Fig. 4: Removing Instrument Cluster  
Courtesy of Toyota Motor Sales, U.S.A., Inc.

## STEERING WHEEL & AIR BAG

### Removal

1) Ensure front wheels are in straight-ahead position. Place ignition switch in LOCK position and remove key. Disconnect and shield negative battery cable. Wait at least 90 seconds before continuing. Remove 2 screw covers from sides of steering wheel. See Fig. 5. Using Torx Wrench (T30), loosen air bag Torx screws until screw head is snug against screw case.

2) Carefully pull air bag away from steering wheel enough to unlock and disconnect air bag electrical connector. DO NOT forcefully pull on electrical connector or wiring. Place air bag aside with pad facing upward.

3) Remove steering wheel lock nut and washer from steering shaft. Make alignment mark on steering shaft and steering wheel for installation reference. Using appropriate steering wheel puller, pull steering wheel from shaft while guiding spiral cable wire through steering wheel opening.

### Installation

1) Ensure front wheels are in straight-ahead position. Turn spiral cable (located on combination switch) counterclockwise by hand until it is hard to turn. Turn spiral cable clockwise about 3 turns and align Red mark at bottom with opening.

2) Guide spiral cable wire through steering wheel opening while installing steering wheel to shaft. Align reference marks on steering shaft and steering wheel. Tighten steering wheel lock nut to 25 ft. lbs. (34 N.m).

3) Connect air bag electrical connector and snap down connector lock. Ensure air bag Torx screws are retracted and snug against screw case. See Fig. 5. Install air bag to steering wheel ensuring wiring is not pinched and does not interfere with other moving parts. Tighten the Torx screws to specification. Refer to the TORX SCREW TORQUE SPECIFICATIONS table. Install screw covers. Connect negative battery cable.

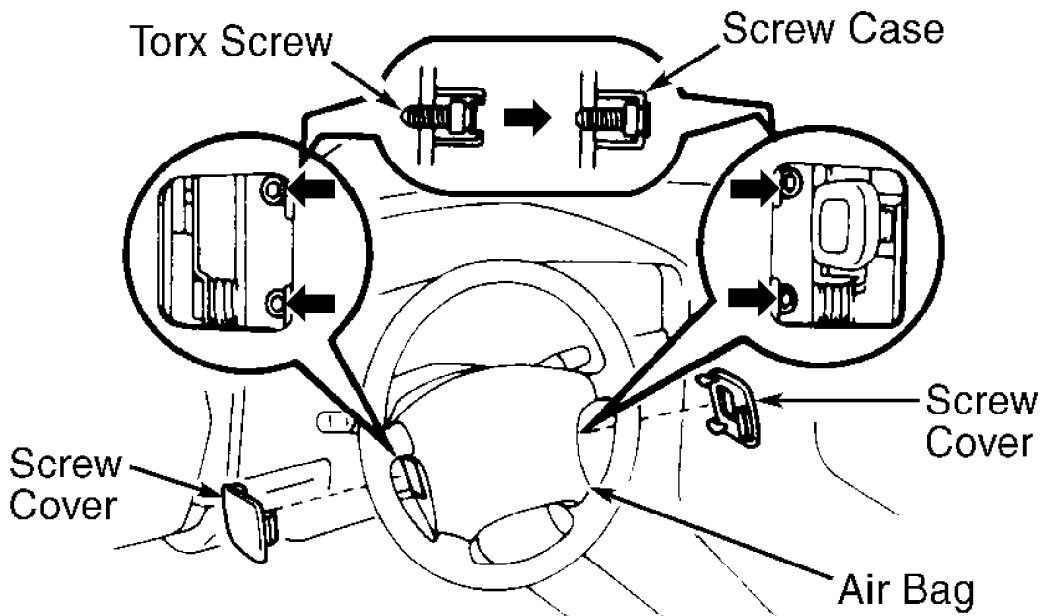

91G03959

Fig. 5: Removing Air Bag From Steering Wheel  
Courtesy of Toyota Motor Sales, U.S.A., Inc.

### TORQUE SPECIFICATIONS



TORX SCREW TORQUE SPECIFICATIONS TABLE

Application	INCH Lbs. (N.m)
Supra .....	78 (8.8)

WIRING DIAGRAMS

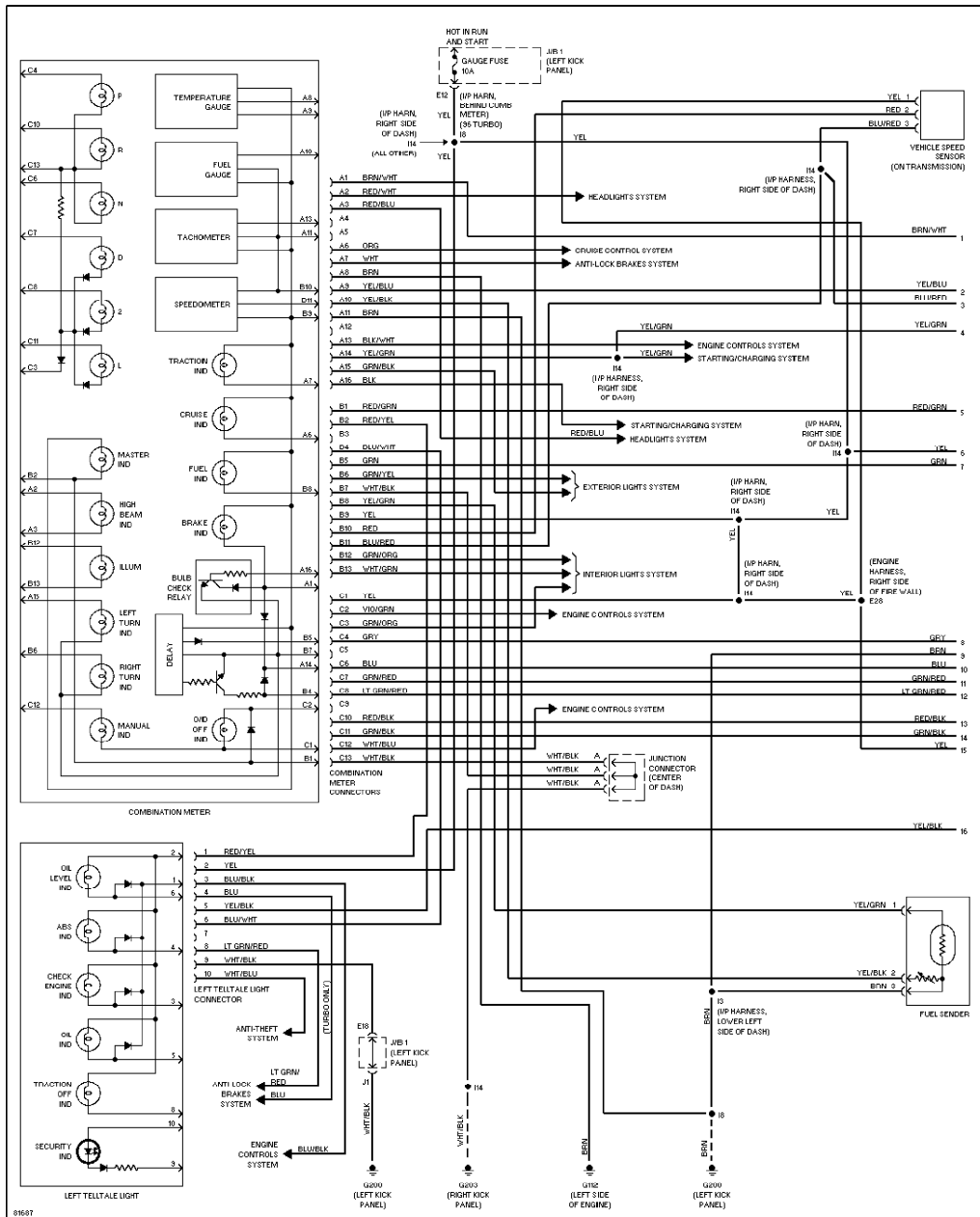

Fig. 6: Instrument Panel Wiring Diagram (1995-96 - 1 Of 2)

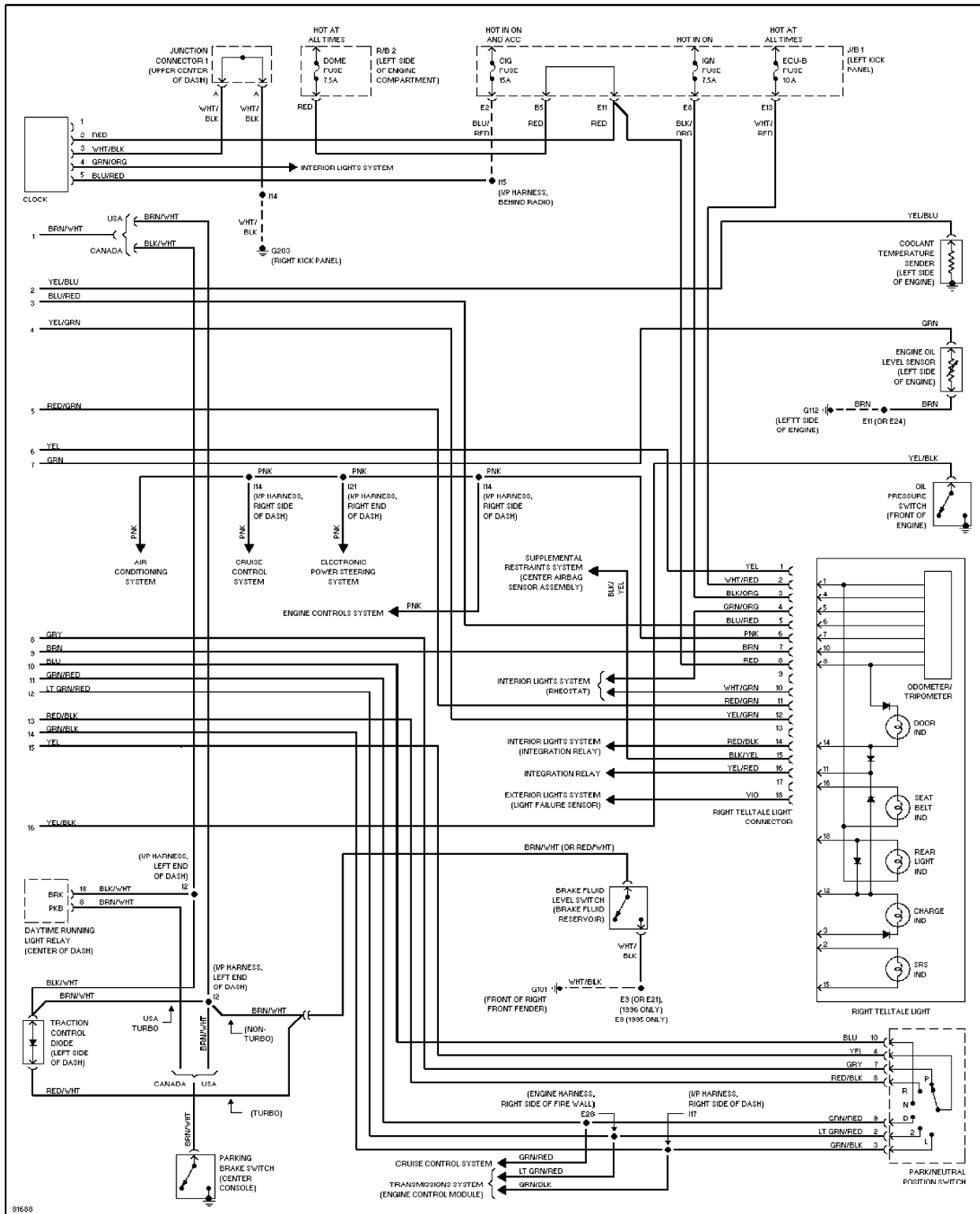

Fig. 7: Instrument Panel Wiring Diagram (1995-96 - 2 Of 2)